

interVOX

Safe & Sound



Two Way Communication Systems for Armored Vehicles

www.inter-vox.com

Intercom & Sirens for Luxury Armored Vehicles

Models: **CN/CNS/CNSH**

(optional with PA)

- ⊕ Enables high quality communication with the exterior of the vehicle through closed windows
- ⊕ Enables hearing conversations outside the vehicle up to 30 m away
- ⊕ 100W output power *(optional)*
- ⊕ Two tone siren (Wail & Yelp) *(optional)*
- ⊕ Hidden installation without modifying the vehicle original appearance
- ⊕ Available with a newly designed remote control or hand held microphone *(optional)*
- ⊕ Low talk button for lower volume output power when discreetness is needed
- ⊕ Comes with our special waterproof loudspeaker for tough conditions
- ⊕ Quick and simple handling and installation



(in & out + siren)



(in & out)



(in & out + siren)

+972 (3) 960-0288 ⊕ info@inter-vox.com ⊕ www.inter-vox.com

interVOX

Safe & Sound

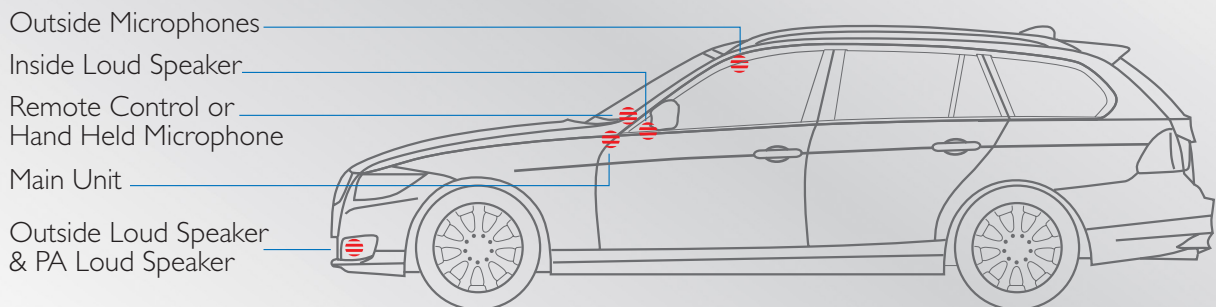

Specifications GYM 12 CN-CNS-CNSH

Operating Supply Voltage	12V DC
Peak Supply Voltage (t = 50 ms)	28V
Output Peak Current (not rep. t = 100 micro s.)	4.5A P/A 12 A
Output Peak Current (rep. f more 10 Hz)	3.5 A P/A 8.5 A
Output Power	25 W
Output Impedance	Between 2–8 Ohms (Normally 4 Ohms)
P/A Output Power	100 W
P/A Output Impedance	Between 4–8 Ohms (Normally 4 Ohms)
Input Power	16 W
Distortion	4 Ohm Po = 0.1 to 10 W Max. 0.5 %
Cross-Talk	f = 1kHz 65 dB f = 10kHz 55 dB
Dimensions	75x95x40 mm
Net Weight	0.6 kg
Inside and Outside Microphones	
Sensitivity	-70±2 dB 0 dB 1V/micro bar. 1 kHz
Impedance	Low impedance
Directivity	Omnidirectional
Frequency range	30–16000 Hz
Operation voltage	6.3V
Current consumption	Max. 0.6 mA
Sensitivity reduction	Within -3 dB at 2V
S/N ratio	>40 dB

The windows of a vehicle are an important asset that protects the driver and passengers.

However, when the driver/passengers need to communicate with someone on the outside, that same window becomes an unwanted barrier.

By using an advanced voice sensor, Intervox systems enable high quality communication with the exterior of the vehicle without compromising driver safety and security.

Our newly designed remote control has a special 3 colors led lightning technology which guarantees simple handling by the driver and provides an excellent look.

All features (intercom, siren, P.A) are operated from the remote control or the hand held microphone to ensure comfortable interface for the driver.

To ensure installation simplicity all the components can be quickly installed in any convenient position on the vehicle.

Adding versatility to efficiency, the systems can be costume tailored to meet your specific needs and are available in 12, 24 and 42 V.D.C.